



Established 1930

Distributors of new & used workshop Equipment

D177 (415V) D177A(240V)

GHD-32

Geared head drill

INSTRUCTION & PARTS MANUAL

9-1-12

GEARED HEAD DRILLING MACHINE

Model **GHD-32**

OWNER'S MANUAL

READ ALL INSTRUCTIONS CAREFULLY

Keep for future reference!

WARNING: FAILURE TO FOLLOW THESE RULES MAY RESULT IN SERIOUS PERSONAL INJURY

As with all machinery there are certain hazards involved with operation and use of the machine. Using the machine with respect and caution will considerably lessen the possibility of personal injury. However, if normal safety precautions are overlooked or ignored, personal injury to the operator may result.

This machine was designed for certain applications only. We strongly recommends that this machine. NOT be modified and/or used for any application other than for which it was designed. If you have any questions relative to its application DO NOT use the machine until you have had detail instruction from your dealer.

SAFETY RULES FOR ALL TOOLS

1. FOR YOUR OWN SAFETY ,READ THIS INSTRUCTION MANUAL BEFORE OPERATING THE TOOL. Learn the tool's application and limitations as well as the specific hazards peculiar to it.
2. KEEP GUARDS IN PLACE and in working order .
3. GROUND ALL TOOLS .If tool is equipped with three-prong plug, it should be plugged into a three-hole electrical receptacle. If an adapter is used to accommodate a two-prong plug receptacle, the adapter lug must be attached to a know ground. Never remove the third prong.
4. REMOVE ADJUSTING AND WRENCHES. Form habit of checking to see that keys and adjusting wrenches are removed from tool before turning it"on."
5. KEEP WORK AREA CLEAN. Cluttered areas and benches invite accidents.
6. DON'T USE IN DANGEROUS ENVIRONMENT .Don't use power tools in damp or wet locations, or expose them to rain. Keep work area well-lighted.
7. KEEP CHILDRE AND VISITORS AWAY. All children and visitors should be keep a safe distance from work area.
8. MAKE WORKSHOP CHILDROOF -with padlocks, master switches, or by removing starter keys.
9. Don't force tool. It will do the job better and be safer at the rate for which it was designed.
10. USE RIGHT TOOL .Don't force tool or attachment to do a job for which

it was not designed.

11. WEAR PROPER APPAREL. No loose clothing, gloves, neckties, rings, bracelets, or other jewelry to get caught in moving parts. Nonslip foot wear is recommended. Wear protective hair covering to contain long hair.

12. ALWAYS WEAR EYE PROTECTION. Refer to ANSIZ87.1 Standard for appropriate recommendations. Also use face or dust mask if cutting operation is dusty.

13. SECURE WORK. Use clamps or a vise to hold work when practical. It's safer than using your hand and frees both hands to operate tool.

14. DON'T OVERREACH. Keep proper footing and balance at all times.

15. MAINTAIN TOOLS IN TOP CONDITION.

Keep tools sharp and clean for best and safest performance. Follow instructions for lubricating and changing accessories.

16. DISCONNECT TOOLS before servicing and when changing accessories such as blades, bits, cutters, ect.

17. USE RECOMMENDED ACCESSORIES.

Consult the owner's manual for recommended accessories. The use of improper accessories may cause hazards.

18. AVOID ACCIDENTAL STARTING. Make sure switch is in "OFF" position before plugging in power cord.

19. NEVER STAND ON TOOL. Serious injury could occur if the tool is tipped or if the cutting tool is accidentally contacted

20. CHECK DAMAGED PARTS. Before further use of the tool, a guard or other part that is damaged should be carefully checked to ensure that it will operate properly and perform its intended function check for alignment of moving parts binding of moving parts, breakage of parts mounting, and any other conditions that may affect its operation. A guard or other part that is damaged should be properly repaired or replaced.

21. DIRECTION OF FEED. Feed work into a blade or cutter against the direction of rotation of the blade or cutter only.

22. NEVER LEAVE TOOL RUNNING UNATTENDED. TURN POWER OFF.

Don't leave tool until it comes to a complete stop.

23. DRUGS, ALCOHOL, MEDICATION. Do not operate tool while under the influence of drug, alcohol or any medication.

24. MAKE SURE TOOL IS DISCONNECTED FROM POWER SUPPLY while motor is being mounted, connected or reconnected.

ADDITIONAL SAFETY RULES FOR MILL DRILL

1. BE SURE drill bit or cutting tool is securely locked in the chuck.
2. BE SURE chuck key is removed from the chuck before turning on power.
3. Adjust the table or depth stop to avoid drilling into the table.
4. SHUT OFF the power ,remove the drill bit or cutting tool, and clean the table before leaving the machine.
5. CAUTION. When practical , use clamps or a vise to secure workpiece to keep the workpiece from rotating while the drill bit or cutting tool.
6. WARNING: FOR Your Own Safety Don't wear gloves when operating a mill/drill.

SPECIFICATION

Drilling capacity		31.5mm(MT3) 40mm(MT4)	
Spindle taper (option)		MT3 , MT4 or R8	
Max.distance from spindle axial to column surface		272.5mm	
Working table size		540mm × 470mm	
Base size		650mm × 450mm	
Dimeter of column		φ 115mm	
Max distance spindle nose to worktable		715mm	
Max distance spindle nose to base		1180mm	
Spindle stroke		120mm	
Spindle speed(rpm) (option)	Motor 0.85KW/1.1KW	I	75 180 280 600 1000 1600
		II	150 360 560 1200 2000 3200
	Motor 1.1KW	50HZ	75 170 280 540 960 1600
		60HZ	90 210 345 670 1180 1970
Packing dimension		740mm × 720mm × 1830mm	
NW/GW Weight		320/370Kg	

WARNING:CHANGE SPEED ONLY WHEN MACHINE IS STOPPED

CHANGING THE GEAR BOX OIL

Tilt the head stock over as shown in Fig 1. Open the drain plug to allow the oil to drain from the opening completely. Then lock the oil drain plug and turn the head to be upright position. Remove the oil filler plug fill the oil

to the gear box until the oil level reach the middle of oil fluid level indicator.
Then lock the plug.

CLEANING

- (1) Your machine has been coated with a heavy grease to protect it in shipping. This coating should be completely removed before operating the machine. Commercial degreaser, kerosene or similar solvent may be used to remove the grease from the machine, but avoid getting solvent on belts or other rubber parts.
- (2) After cleaning, coat all bright work with a light lubrication . Lubricate all points with a medium consistency machine oil.

LUBRICATION:

All ball bearings in your mill/drill are sealed for life ,requiring no lubrication.
Points requiring lubrication are:

- (1) Internal spline drive assembly. Keep this area well lubricated with a good grade grease , insert grease in the hole at the top of spindle pulley spline driver, lube twice yearly.
- (2) A light film of oil applied to the quill and column will reduce wear, prevent rust, and assure ease of operation.
- (3) Quill return spring should receive oil(sae 20) once yearly. Remove cover plate and apply oil with squirt can or small brush.
- (4) **IMPORTANT:** The gear box should be oiled with a lubricant such as sae 68 oil in level. **CHANGE OIL EVERY ONE YEAR.**
- (5) Apply lubriplate to quill pinion every 90 days.

NOTE: use extreme care when performing this operation and keep hands clear of pinch points. When using paraffin bar, do this only by turning the sheaves by hand. Do not apply with motor running.

USE OF MAIN MACHINE PARTS

- (1) To raise and lower the head by head handle.
- (2) Equipped with an electric switch for tapping operation clockwise or counterclock wise.
- (3) To adjust the quick or slow feeding by feed handle.
- (4) To adjust the table left and right travel by table handle wheel.
- (5) To adjust the table fore and after travel by table handle wheel.
- (6) To operate the spindle handle wheel for micro feed.
- (7) To adjust the scale size according to working need.

PRECAUTION FOR OPERATION

Check all parts for proper condition before operation; if normal safety precautions are noticed carefully, this machine can provide you withstanding of accurate service.

(1) Before Operation

- (a) Fill the lubricant
- (b) In order to keep the accurate precision, the table must be free from dust and oil deposits.
- (c) Check to see that the tools are correctly set and the workpiece is set firmly.
- (d) Be sure the speed is not set too fast.
- (e) Be sure everything is ready before use

(2) After Operation

- (a) Turn off the electric switch.
- (b) Turn down the tools.
- (c) Clean the machine and coat it with lubricant.
- (d) Cover the machine with cloth to keep out the dust.

(3) Adjustment of head

- (a) To raise and lower the head, loosen the leaf screw located on the right side of the raise and lower base. When the desired height is reached tighten leaf screw to avoid vibration.
- (b) Head may be rotated 360° by loosening the same bolts mentioned above. Adjust the head to the desired angle, then fix the heavy duty head locknuts, It is tighten the same to fix the head if drilling & milling too much.
- (c) Unscrew 3 nuts while the workpiece needs to be drilled. Turn to the degrees you wish on the scale, then screw the 3 nuts.

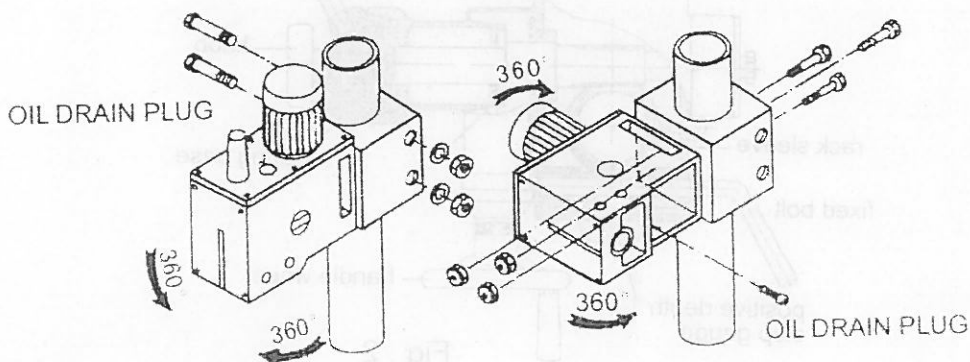

Fig.1

(4) Adjustment of the lifting table

- (a) Loosening the locking handles, rocking the crank to move the lifting table up and down along the column, when arrived the height of your request, tighten the handles to prevent loose.
- (b) When need to working large parts, loosening the locking handles, rotating the lifting table of 180° , then tighten the handles, and place the part on the base to work on it.

QUILL RETURN SPRING ADJUSTMENT:

Spring tension for return of spindle, after hole drilling, has been pre-set at the factory .No further adjustment should be attempted unless absolutely necessary. Adjustment will probably be required if a multiple spindle drilling or tapping head is used .If adjustment is necessary ,loosen lock screw while holding quill spring housing .Do not allow the housing to turn in your hand, or spring will unwind. Turn entire housing assembly clockwise the number of turns necessary to cause the quill to return to its up position.(NOTE: The flat of the spring housing pilot is lined up with the spring loading hole on the body of the spring housing.)Reset lockscrew make sure point of screw mates the flat on the housing journal.

(1)Preparing for Drilling(see fig.2)(Except addition power feed system).

Turn of the knob make loose the taper body of worm gear and spring base. Then we decide spindle stroke setting the positive depth stop gauge for drilling blind hole or free state for pass hole.

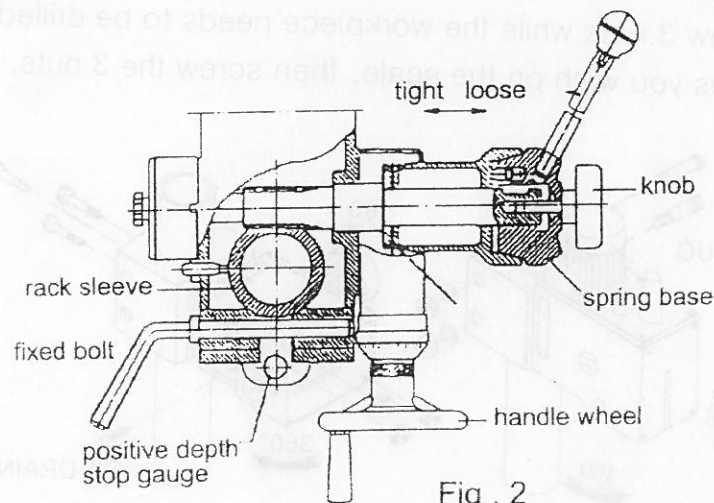

Fig . 2

TRUBLE SHOOTING HINTS

TO CHANGE TOOLS

(1) Removing Face Mill or Drill Chuck Arbor

Loosen the arbor bolt at the top of the spindle shaft approximately 2 turns with a wrench. Rpa the top of the arbor bolt with a mallet.

After taper has been broken loose, holding chuck arbor on hand and turn detach the arbor bolt with the other hand.

(2) Removing Taper Drills

(a) Turn down the arbor bolt and insert the taper drill into the spindle shaft.

(b) Turn the rapid down handle rod down until the oblong hole in the rack sleeve appears. Line up this hole with the hole in the spindle. Insert key punch key through holes and strike lightly lightly with a mallet. This will force the taper drill out.

TROUBLE SHOOTING HINTS

TROUBLE	PROBABLE CAUSE	REMEDY
Excessive Vibration	<ol style="list-style-type: none"> 1. Motor out of balance 2. Bad motor 	<ol style="list-style-type: none"> 1. Balance or replace problem motor. 2. Replace motor
Motor stalls	<ol style="list-style-type: none"> 1. Over feeding. 2. Dull drill. 3. Motor not building up to running speed 4. Bad motor 	<ol style="list-style-type: none"> 1. Reduce feed rate. 2. Sharpen drill and keep sharp. 3. Replace or repair motor. Check fuses in all three legs on three phase motors and replace if necessary. 4. Replace motor.
Noisy Operation	<ol style="list-style-type: none"> 1. Excessive vibration. 2. Improper quill adjustment. 3. Noisy spline 4. Noisy motor 	<ol style="list-style-type: none"> 1. Check remedy under excessive vibration. 2. Adjust quill. 3. Lubricate spline. 4. Check motor bearings or for loose motor fan.
Drill or Tool heats up or burns work.	<ol style="list-style-type: none"> 1. Excessive speed. 2. Chips not clearing. 3. Dull tool. 4. Feed reate too slow. 5. Rotation of drill incorrect. 6. Failure to use cutting oil or coolant(on steel) 	<ol style="list-style-type: none"> 1. Reduce speed. 2. Use pecking operation to clear chips. 3. Sharpen tool or replace. 4. Incresase feed enough to clear chips. 5. Reverse motor rotation. 6. Use cutting oil or coolant on steel
Drill leads off	<ol style="list-style-type: none"> 1. No drill spot. 2. Cutting lips on drill off center. 3. Quill loose in head. 4. Bearing play. 	<ol style="list-style-type: none"> 1. Center punch or center drill workpiece. 2. Regrind drill. 3. Tighten quill. 4. Check bearings and reseal or replace if necessary.
Excessive drill runout or wobble	<ol style="list-style-type: none"> 1. Bent drill. 2. Bearing play. 3. Drill not seated properly in chucks. 	<ol style="list-style-type: none"> 1. Replace drill. Do not attempt to straighten 2. Replace or reseal bearings. 3. Loosen, reseal and tighten chuck.
Work or fixture comes loose or spins	<ol style="list-style-type: none"> 1. Failure to clamp workpiece or work holding device to table. 	<ol style="list-style-type: none"> 1. Clamp workpiece or work holding device to table surface.

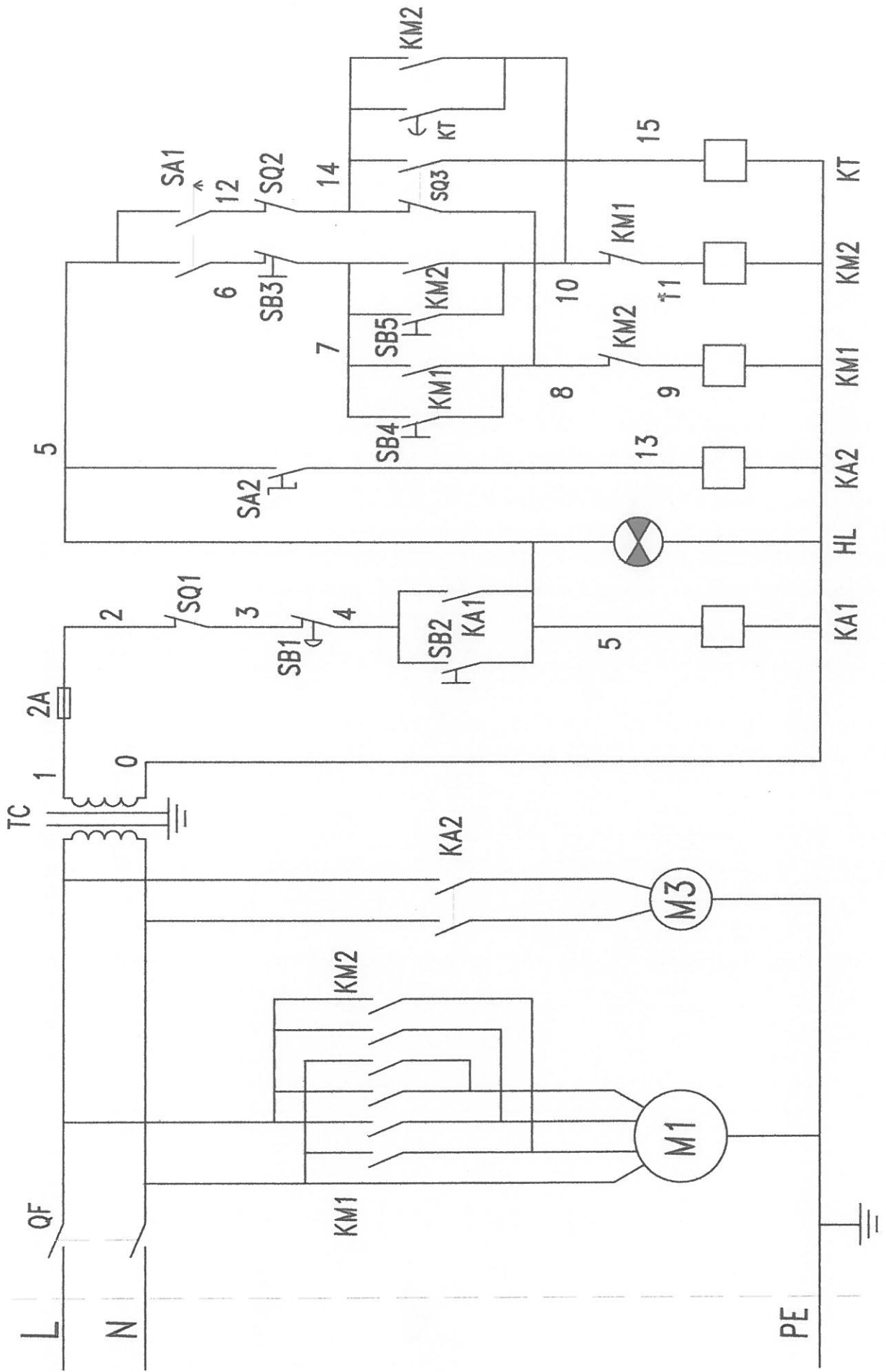

240V WIRING DIAGRAM

415V

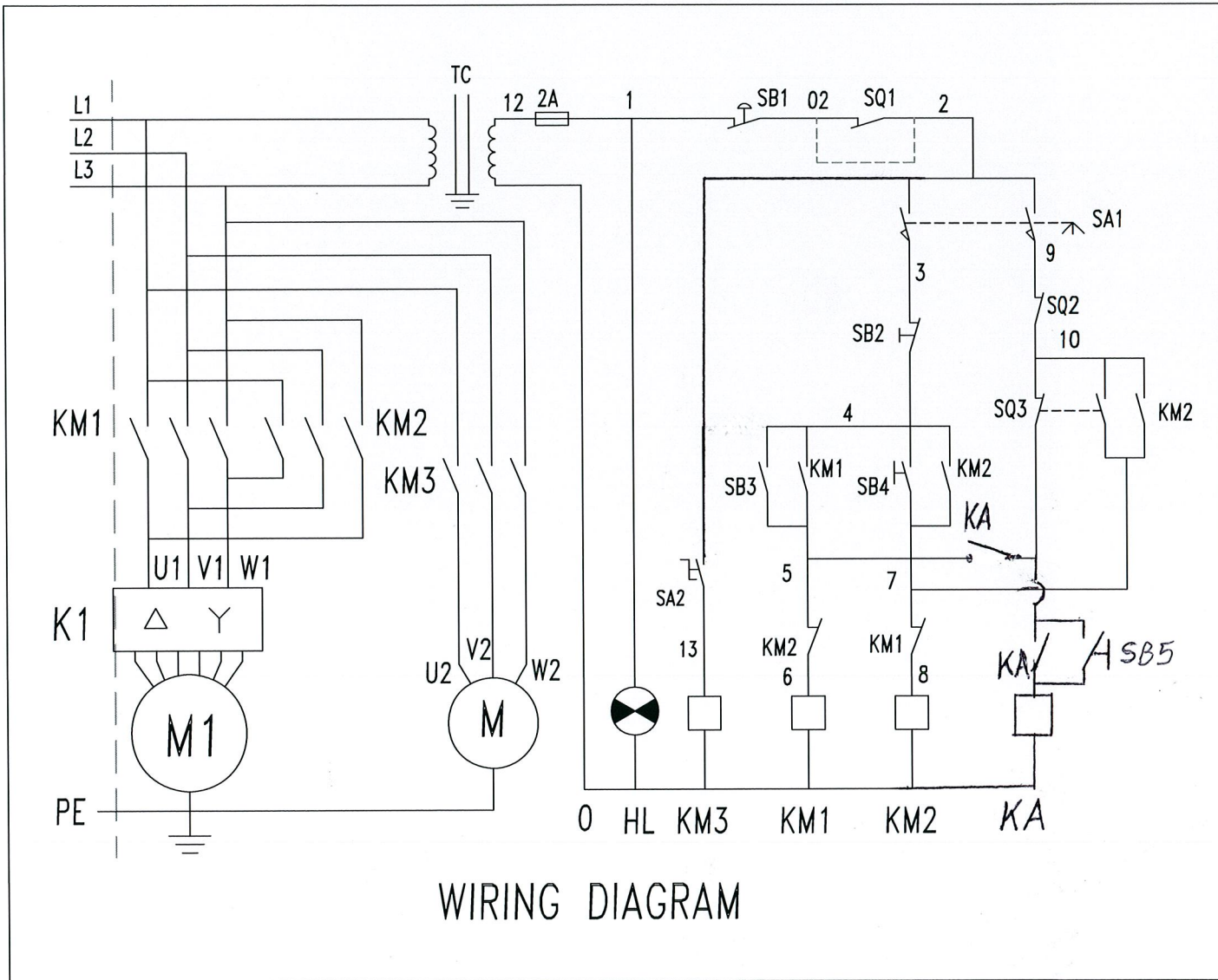

Power feed device

This machine be equipped with the Power feed device see Fig.1.

- 1.Power feed switch
- 2.Speed lever
- 3.Spindle stroke dial
- 4.Handle
- 5.Limited screw
- 6.Locked nut
- 7.Micro feed dial
- 8.Locked screw
- 9.Hand wheel

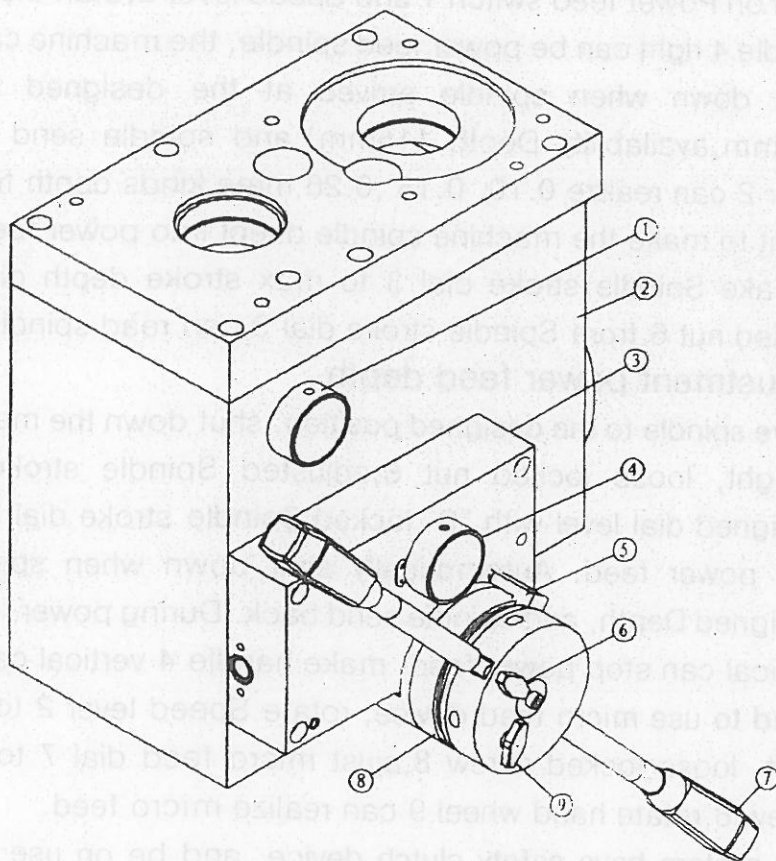

Fig.1.

OPERATION PROCEDURE

Manual feed

Turn the Power feed switch 1 off, handle 4 will be vertical with the axis of Spindle stroke dial 3, rotate limited screw 5 and be contacted with handle 4, then can be manually feed spindle.

When the Power feed switch 1 on, make handle 4 vertical, locked limited screw 5, rotate Speed lever 2 to "0", then can be manually feed spindle.

When want to trade off manual feed and power feed, stop the machine and turn on Power feed switch 1 and Speed lever 2. Make handle 4 vertical can be manually feed Spindle, Push handle 4 right can be power feed Spindle.

Power feed

Turn on Power feed switch 1 and Speed lever 2, Start the machine and push handle 4 right can be power feed spindle, the machine can be automatically shut down when spindle arrived at the designed Depth. (max Depth 120mm, availability Depth 115mm), and spindle send back. Turn Speed lever 2 can realize 0.10, 0.18, 0.26 three kinds depth feed to choose.

Want to make the machine spindle direct into power feed, loose lock nut 6, make Spindle stroke dial 3 to max stroke depth dial position, tighten lock nut 6 from Spindle stroke dial 3 can read spindle the position.

Adjustment power feed depth

Move spindle to the designed position, shut down the machine. Push handle 4 right, loose lock nut 6, adjusted Spindle stroke dial 3, make the designed dial level with "0", locked Spindle stroke dial 3, start the machine can power feed. Automatically shut down when spindle arrived at the designed Depth, and spindle send back. During power feed, make handle 4 vertical can stop power feed. make handle 4 vertical can stop power feed.

Need to use micro feed device, rotate Speed lever 2 to "0", push handle 4 right, loose lock screw 8, adjust micro feed dial 7 to "0", tighten lock screw 8, rotate hand wheel 9 can realize micro feed.

The system have safety clutch device, and be on use estate before leave factory. When clutch invalidation because of fray, and want to adjustment, can take away the panel and adjust spring can immediately recover the function.

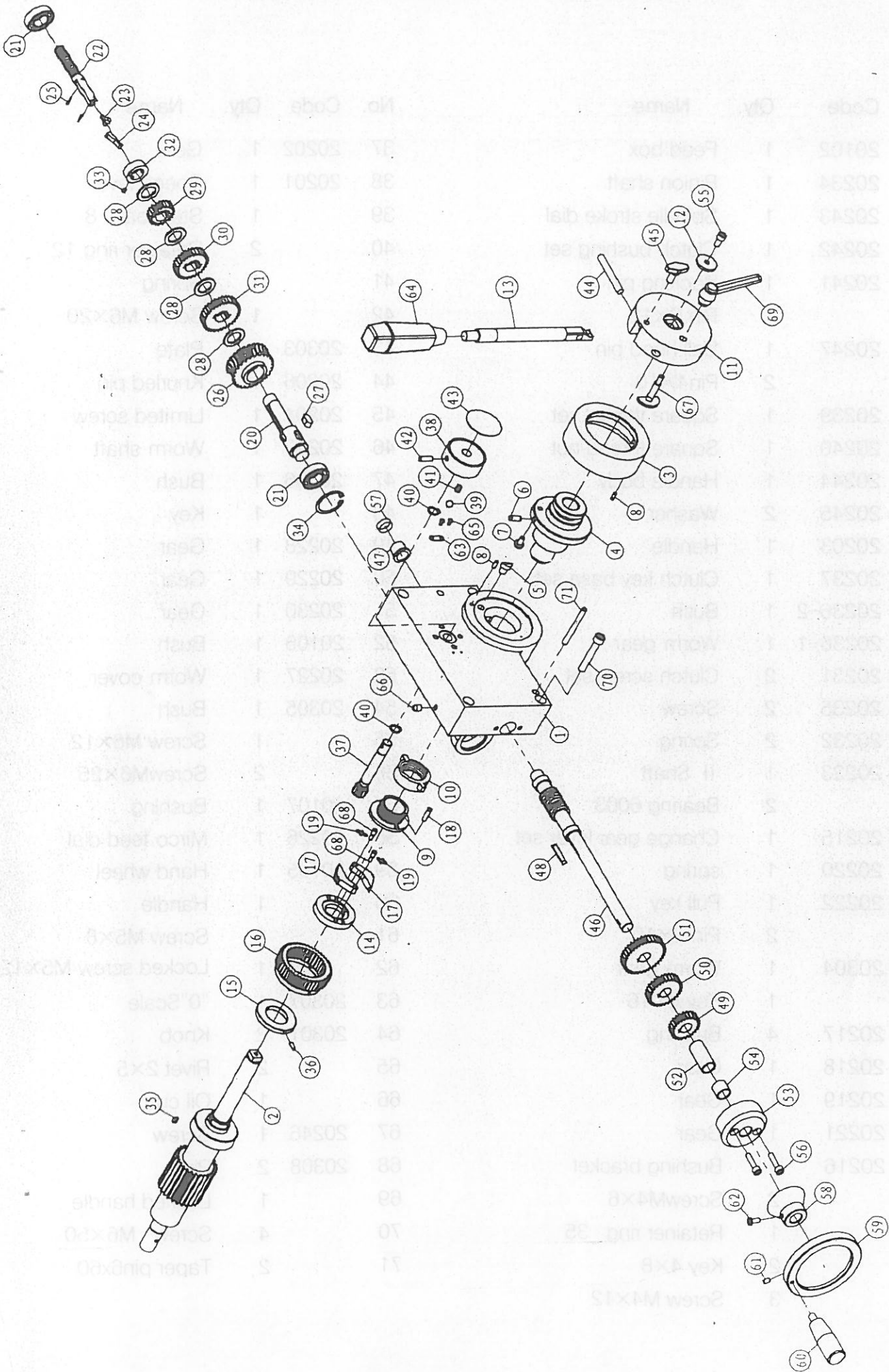

No.	Code	Qty.	Name	No.	Code	Qty.	Name
1	20102	1	Feed box	37	20202	1	Gear
2	20234	1	Pinion shaft	38	20201	1	Speed lever
3	20243	1	Spindle stroke dial	39		1	Steel ball 8
4	20242	1	Clutch bushing set	40		2	Retainer ring 12
5	20241	1	Backing pin	41		1	Spring
6		1	Pin 6×12	42		1	Screw M6×20
7	20247	1	Ball head pin	43	20303	1	Plate
8		2	Pin4×10	44	20206	1	Knurled pin
9	20239	1	Square thread set	45	20204	1	Limited screw
10	20240	1	Square thread nut	46	20233	1	Worm shaft
11	20244	1	Handle body	47	20306	1	Bush
12	20245	2	Washer	48		1	Key
13	20203	1	Handle	49	20228	1	Gear
14	20237	1	Clutch key base set	50	20229	1	Gear
15	20236-2	1	Bush	51	20230	1	Gear
16	20236-1	1	Worm gear	52	20106	1	Bush
17	20231	2	Clutch screw set	53	20227	1	Worm cover
18	20235	2	Screw	54	20305	1	Bush
19	20232	2	Spring	55		1	Screw M6×12
20	20223	1	II Shaft	56		2	ScrewM6×25
21		2	Bearing 6003	57	20107	1	Bushing
22	20215	1	Change gear lever set	58	20226	1	Mirco feed dial
23	20220	1	spring	59	20105	1	Hand wheel
24	20222	1	Pull key	60		1	Handle
25		2	Pin 2×10	61		1	Screw M5×8
26	20304	1	Worm gear	62		1	Locked screw M5×12
27		1	Key 8×16	63	20307	1	"0"Scale
28	20217	4	Bushing	64	20301	2	Knob
29	20218	1	Gear	65		2	Rivet 2×5
30	20219	1	Gear	66		1	Oil cup
31	20221	1	Gear	67	20246	1	Screw
32	20216	1	Bushing bracket	68	20308	2	Pin
33		2	ScrewM4×6	69		1	Locked handle
34		1	Retainer ring 35	70		4	Screw M6×50
35		2	Key 4×8	71		2	Taper pin6×60
36		3	Screw M4×12				

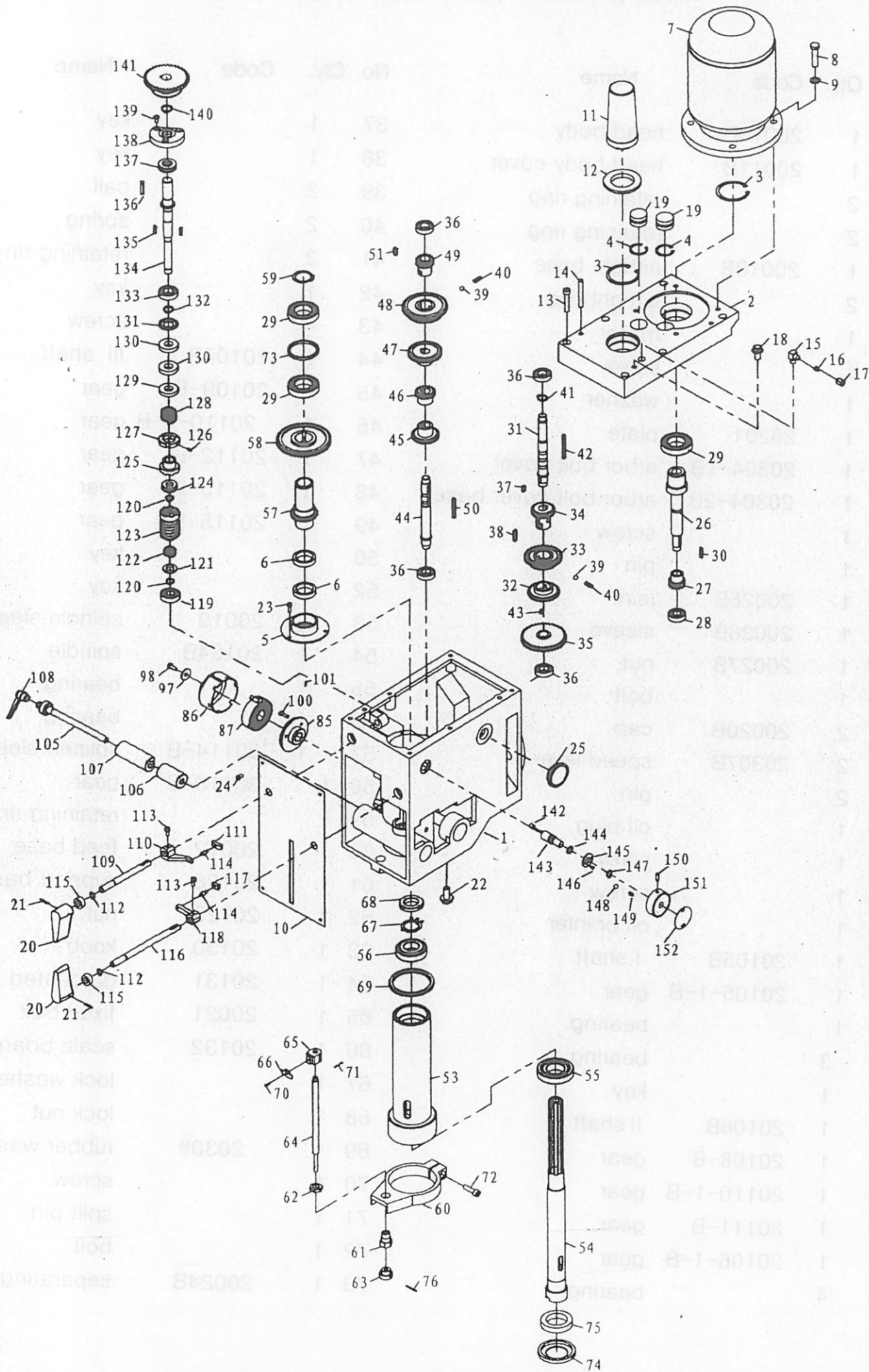

Head parts for spindle power feed

No.	Qty.	Code	Name	No.	Qty.	Code	Name
1	1	20010B	head body	37	1		key
2	1	20011B	head body cover	38	1		key
3	2		retaining ring	39	2		ball
4	2		retaining ring	40	2		spring
5	1	20018B	airtight base	41	2		retaining ring
6	2		airtight ring	42	1		key
7	1		motor	43	4		screw
8	1		screw	44	1	20107B	III shaft
9	1		washer	45	1	20109-B	gear
10	1	20201	plate	46	1	20110-2-B	gear
11	1	20304-1B	arbor bolt cover	47	1	20112-B	gear
12	1	20304-2B	arbor bolt cover base	48	1	20113-B	gear
13	1		screw	49	1	20115-B	gear
14	1		pin	50	1		key
15	1	20025B	joint	52	1		key
16	1	20026B	sleeve	53	1	20019	spindle sleeve
17	1	20027B	nut	54	1	20104B	spindle
18	1		bolt	55	1		bearing
19	2	20020B	cap	56	1		bearing
20	2	20307B	speed lever	57	1	20114-B	splined sleeve
21	2		pin	58	1	20116-B	gear
22	1		oil plug	59	1		retaining ring
23	1		screw	60	1	20012	feed base
24	1		screw	61	1	20128	support base
25	1		oil pointer	62	1	20129	nut
26	1	20105B	I shaft	63	1	20130	knob
27	1	20105-1-B	gear	64	1	20131	graduated rod
28	1		bearing	65	1	20021	fixed bolt
29	3		bearing	66	1	20132	scale board
30	1		key	67	1		lock washer
31	1	20106B	II shaft	68	1		lock nut
32	1	20108-B	gear	69	1	20308	rubber washer
33	1	20110-1-B	gear	70	1		screw
34	1	20111-B	gear	71	1		split pin
35	1	20106-1-B	gear	72	1		bolt
36	4		bearing	73	1	20024B	separating ring

Head parts for spindle power feed

No.	Qty.	Code	Name	No.	Qty.	Code	Name
74	1	20133B	oil tight cover	131	1	20103A	washer
75	1		air tight	132	1		retaining ring
76	1		pin	133	1		bearing
85	1	20118	spring base	134	1	20213A	I shaft
86	1	20123	spring cap	135	2		key
87	1	20122	spring plate	136	1		key
97	1	20102	washer	137	1		bearing
98	1		bolt	138	1	20104A	flange
100	1		screw	139	3		screw
101	2		pin	140	1		retaining ring
105	1	20124B	fixed bolt	141	1	20212A	gear
106	1	20203B	fixed tight block	142	1	20109A	quill
107	1	20202B	fixed tight block	143	1	20214A	lever shaft
108	1		adjust handle	144	1		O-airtight
109	1	20125B	lever shaft	145	1	20250	flange cover
110	1	20022-1B	lever	146	2		screw
111	1	20204-2B	lever bracket	147	1		retaining ring
112	2		retaining ring	148	1		steel ball
113	2		screw	149	1		spring
114	2	20204-3B	lever rod	150	1		screw
115	2		oil seal	151	1	20201	speed lever
116	1	20126B	long lever shaft	152	1	20303	label
117	1	20204-1B	lever bracket				
118	1	20022-2B	lever				
119	1		bearing				
120	2		retaining ring				
121	1		washer				
122	1	20209	spring				
123	1	20207A	worm shaft				
124	1		bearing				
125	1	20208B	clutch base				
126	3		screw				
127	1		locked nut				
128	1	20205B	spring				
129	1	20108A	fixed sleeve				
130	2		oil seal				

WARNING

General Machinery Safety Instructions

Machinery House
requires you to read this entire Manual before using this machine.

- 1. Read the entire Manual before starting machinery.** Machinery may cause serious injury if not correctly used.
- 2. Always use correct hearing protection when operating machinery.** Machinery noise may cause permanent hearing damage.
- 3. Machinery must never be used when tired, or under the influence of drugs or alcohol.** When running machinery you must be alert at all times.
- 4. Wear correct Clothing.** At all times remove all loose clothing, necklaces, rings, jewelry, etc. Long hair must be contained in a hair net. Non-slip protective footwear must be worn.
- 5. Always wear correct respirators around fumes or dust when operating machinery.** Machinery fumes & dust can cause serious respiratory illness. Dust extractors must be used where applicable.
- 6. Always wear correct safety glasses.** When machining you must use the correct eye protection to prevent injuring your eyes.
- 7. Keep work clean and make sure you have good lighting.** Cluttered and dark shadows may cause accidents.
- 8. Personnel must be properly trained or well supervised when operating machinery.** Make sure you have clear and safe understanding of the machine you are operating.
- 9. Keep children and visitors away.** Make sure children and visitors are at a safe distance for you work area.
- 10. Keep your workshop childproof.** Use padlocks, Turn off master power switches and remove start switch keys.
- 11. Never leave machine unattended.** Turn power off and wait till machine has come to a complete stop before leaving the machine unattended.
- 12. Make a safe working environment.** Do not use machine in a damp, wet area, or where flammable or noxious fumes may exist.
- 13. Disconnect main power before service machine.** Make sure power switch is in the off position before re-connecting.
- 14. Use correct amperage extension cords.** Undersized extension cords overheat and lose power. Replace extension cords if they become damaged.
- 15. Keep machine well maintained.** Keep blades sharp and clean for best and safest performance. Follow instructions when lubricating and changing accessories.
- 16. Keep machine well guarded.** Make sure guards on machine are in place and are all working correctly.
- 17. Do not overreach.** Keep proper footing and balance at all times.
- 18. Secure workpiece.** Use clamps or a vice to hold the workpiece where practical. Keeping the workpiece secure will free up your hand to operate the machine and will protect hand from injury.
- 19. Check machine over before operating.** Check machine for damaged parts, loose bolts, Keys and wrenches left on machine and any other conditions that may effect the machines operation. Repair and replace damaged parts.
- 20. Use recommended accessories.** Refer to instruction manual or ask correct service officer when using accessories. The use of improper accessories may cause the risk of injury.
- 21. Do not force machinery.** Work at the speed and capacity at which the machine or accessory was designed.
- 22. Use correct lifting practice.** Always use the correct lifting methods when using machinery. Incorrect lifting methods can cause serious injury.
- 23. Lock mobile bases.** Make sure any mobile bases are locked before using machine.
- 24. Allergic reactions.** Certain metal shavings and cutting fluids may cause an allergic reaction in people and animals, especially when cutting as the fumes can be inhaled. Make sure you know what type of metal and cutting fluid you will be exposed to and how to avoid contamination.
- 25. Call for help.** If at any time you experience difficulties, stop the machine and call you nearest branch service department for help.



WARNING

Drilling Machine Safety Instructions

Machinery House
requires you to read this entire Manual before using this machine.

- 1. Maintenance.** Make sure the Drill is turned off and disconnect from the main power supply and make sure all moving parts have come to a complete stop before any inspection, adjustment or maintenance is carried out.
- 2. Drill Condition.** Drill must be maintained for a proper working condition. Never operate a Drill that has damaged or worn parts. Scheduled routine maintenance should be performed on a scheduled basis.
- 3. Leaving a Drill Unattended.** Always turn the Drill off and make sure all moving parts have come to a complete stop before leaving the Drill. Do not leave Drill running unattended for any reason.
- 4. Avoiding Entanglement.** Remove loose clothing, belts, or jewelry items. Never wear gloves while machine is in operation. Tie up long hair and use the correct hair nets to avoid any entanglement with the Drill spindle or moving parts.
- 5. Chuck key & wrench safety.** Always remove chuck keys, wrenches and any service tools immediately after use. Chuck keys left in the chuck can cause serious injury.
- 6. Understand the machines controls.** Make sure you understand the use and operation of all controls.
- 7. Drill bit selection.** Always use the correct Drill bit for the job you are Drilling. Make sure you use the correct shank drill bit for your drilling machine.
- 8. Secure the Drill Bit.** Properly tighten and securely lock the drill bit in the chuck.
- 9. Cutting Tool inspection.** Inspect Drill for sharpness, chips, or cracks before use. Replace any cutting tools immediately if dull, chipped or cracked. Handle new cutting tools with care. Cutting edges are very sharp and can cause lacerations.
- 10. Reversing the spindle.** Make sure the spindle has come to a complete stop before changing the direction of the spindle.
- 11. Stopping the spindle.** Do not slow or stop the spindle by using your hand.
- 12. Speed selection.** Select the appropriate speed for the type of work, material, and tool bit. Allow the Drill to reach full speed before beginning a cut.
- 13. Changing Belts for speed selection.** Always allow the machine to come to a complete stop and turn power off before changing belts. Not turning power off when changing belts can cause serious injury.
- 14. Clearing chips.** Always use a brush to clear chips. Never clear chips when the drill is running.
- 15. Power outage.** In the event of a power failure during use of the drill, turn off all switches to avoid possible sudden start up once power is restored.
- 16. Clean work area.** Keep the area around the drill clean from oil, tools, chips.
- 17. Surface/workpiece area.** Before turning the drill on, make sure the table is clear of any objects (tools, scraps, off-cuts etc.) Do not drill material that does not have a flat surface unless a suitable support is used.
- 18. Table Lock.** Make sure the table is tightened before starting the drill.
- 19. For - Radial Drill Arm Lock.** Make sure the arm is locked before leaving or starting a radial arm drill. An unlocked radial drill arm can swing and cause serious injury.
- 20. Drilling Sheet metal.** All sheet metal should be clamped to the table before drilling.
- 21. Mounting workpieces.** Use clamps or vices to secure workpiece before drilling. Position work so you avoid drilling into table.
- 22. Guarding.** Do not operate the drill when chuck guard is removed.
- 23. Eye and hand protection.** A face shield with safety glasses is recommended. Always keep hands and fingers away from the drill bit. Never hold a workpiece in your hand while drilling. Do not wear gloves while operating the drill.
- 24. Drill operation.** Never start the drill with the drill bit pressed against the workpiece. Feed the drill evenly into the workpiece. Back the drill out of deep holes. Turn the machine off and clear chips and scrap pieces with a brush. Turn power off, remove drill bit, and clean the table before leaving the machine.
- 25. Call for help.** If at any time you experience difficulties, stop the machine and call your nearest branch service department for help.

PLANT SAFETY PROGRAM

NEW MACHINERY HAZARD IDENTIFICATION, ASSESSMENT & CONTROL

Drilling Machine

Developed in Co-operation Between A.W.I.S.A and Australia Chamber of Manufactures
This program is based upon the Australian Worksafe Standard for Plant(NOHSC:1010-1994)

Item No.	Hazard Identification	Hazard Assessment	Risk Control Strategies <small>(Recommended for Purchase / Buyer / User)</small>
A	ENTANGLEMENT	HIGH	Eliminate, avoid loose clothing / Long hair etc.
B	CRUSHING	LOW	Secure & support work material on drill table.
C	CUTTING, STABBING, PUNCTURING.	MEDIUM	Isolate power to machine prior to any checks or maintenance being carried out. Do not adjust or clean until the machine has fully stopped.
D	SHEARING	MEDIUM	Isolate power to machine when changing speeds or maintenance is being carried out. Make sure all guards are secured shut when machine is on.
F	STRIKING	MEDIUM	Ensure workpieces are tightly secured on machine. Wear safety glasses. For Radial Arm Drills ensure that arm is locked before drilling. Ensure correct spindle direction when drilling..
H	ELECTRICAL	MEDIUM	All electrical enclosures should only be opened with a tool that is not to be kept with the machine. Never clean or dust machine when power is on. Machine should be installed & checked by a Licensed Electrician.
M	HIGH TEMPERATURE	LOW	Wear appropriate protective clothing to prevent hot swarf.
O	OTHER HAZARDS, NOISE.	LOW	Wear hearing protection as required.
Plant Safety Program to be read in conjunction with manufactures instructions			



www.machineryhouse.com.au



www.machineryhouse.co.nz

Authorised and signed by:
Safety officer:

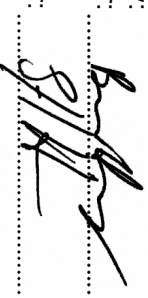

Manager:

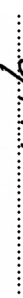

Revised Date: Aug-08